



**PERFORMANCE DATA SHEET
NEMA PREMIUM NR CAN NEMA 12 - 12**

Catalogue #: MQSP-506TL

HP	kW	Voltage	S.F. @ 60Hz	Efficiency	Power Factor	Frame	Design	L.R. Amps
5	3,73	230/460	1,15	89,5%	0,769	215TC	B	46

60 Hz								
FLA							Code	F.L. RPM
208	230	416	460	480	575	600		
/	13,6	/	6,8	/	/	/	J	1175

50 Hz								
FLA			S.F. @ 50Hz	Efficiency	Power Factor	Code	F.L. RPM	
190	380	415						
16,6	8,3	/	1,00	87,5%	0,78	J	960	

Wgt. Lbs	PH	Duty	Insul. Class	Amb.	Elevation	Temp. Rise° C
171	3	Cont.	F	40°C	1000M (3300 Ft)	< 80

% Efficiency		% Power Factor		Torque		Winding Resist. Ω	Safe Cold Start (Secs)
Full Load:	89,5%	Full Load:	0,77	Full Load Ft/Lbs	22,3		
3/4 Load:	89,8%	3/4 Load:	0,74	Locked Rotor %	200		
1/2 Load:	88,9%	1/2 Load:	0,62	Break Down %	250	0	12

Rotor Inertia Wk2 Lb-Ft2	Max Load Inertia Wk2 Lb-Ft2	Shaft Material	Frame Material	DE Bracket Type	ODE Bracket Type	Enclosure	NEMA Rating	Lead Wire Size
0,85	103	304SS	Stainless Steel			TEFC	IP69K	14 AWG

Ball Bearings		Grease	Mount Type	Orientation	Paint	Sound Pressure @ 3FT	Sound Power
DE	ODE						
6308	6208	Sealed Bearings	Foot	Horizontal	-	61	71

Inverter Duty. Motor meets MG1 parts 31.4.4.2	Constant Torque Range	Variable Torque Range	Constant HP RPM
	10:1	20:1	1800

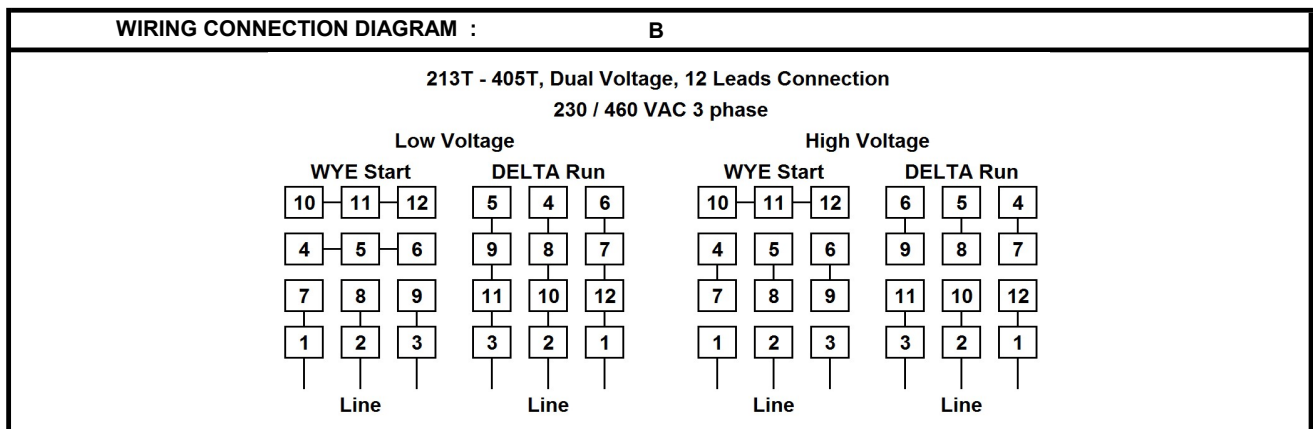

Date: 2024-01-29
 Customer: _____
 Contact: _____
 Submittee: J.C. Lavallée

Catalogue #: **MQSP-506TL**

NEMA PREMIUM NR CAN NEMA 12 - 12										
HP	VAC	RPM	Enclosure	Frame	Frequency	Design	Poles	LR Code Letter	Insulation Class	Temp. Rise °C
5	460	1175	TEFC	215TC	60	B	6	J	F	< 80
	0Hz	6Hz	15Hz	30Hz	45Hz	60Hz	75Hz	90Hz	105Hz	120Hz
Amps	6,8	6,8	6,8	6,8	6,8	6,8	6,8	6,8	6,8	6,8
RPM	0	117,5	293,75	587,5	881,25	1175	1468,75	1762,5	2056,25	2350
Torq ft.lb	17,88	17,88	22,35	22,35	22,35	22,35	17,88	14,90	12,77	11,17
Peak Tq ft.lb	27,38	54,75	54,75	54,75	54,75	54,75	#REF!	#REF!	#REF!	#REF!
HP	0	0,4	1,3	2,5	3,8	5,0	5,0	5,0	5,0	5,0
	Locked Rotor	Pull-Up	Breakdown	Rated Load	Idle	Duty	S. F.	Ambient	Elevation	dBA @ 1M
Speed (RPM)	0,0	504	960	1175	1200	Continuous	1,15	40°C	3,300 ft	61
Current (Amps)	46,0	39,1	27,4	6,8	2,6	VFD Rating: Meets MG1 parts 31.4.4.2				
Torque (ft-lbs)	53,6	45,6	64,8	22,3	0,0	CT	10:1	VT	20:1	

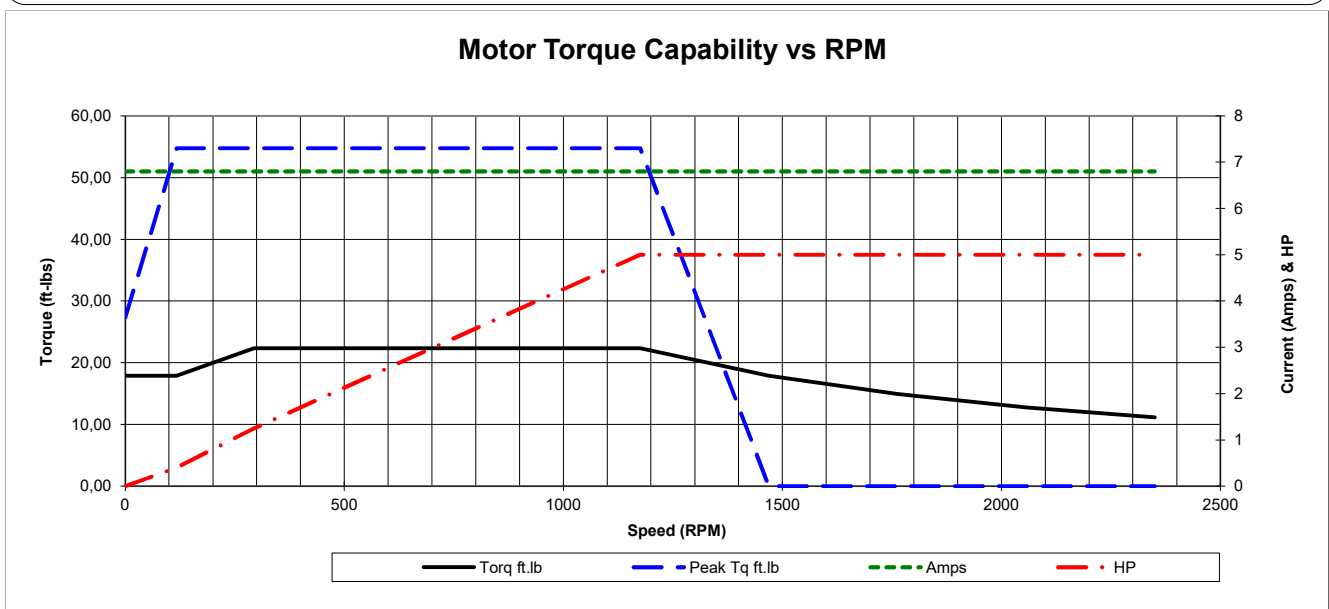
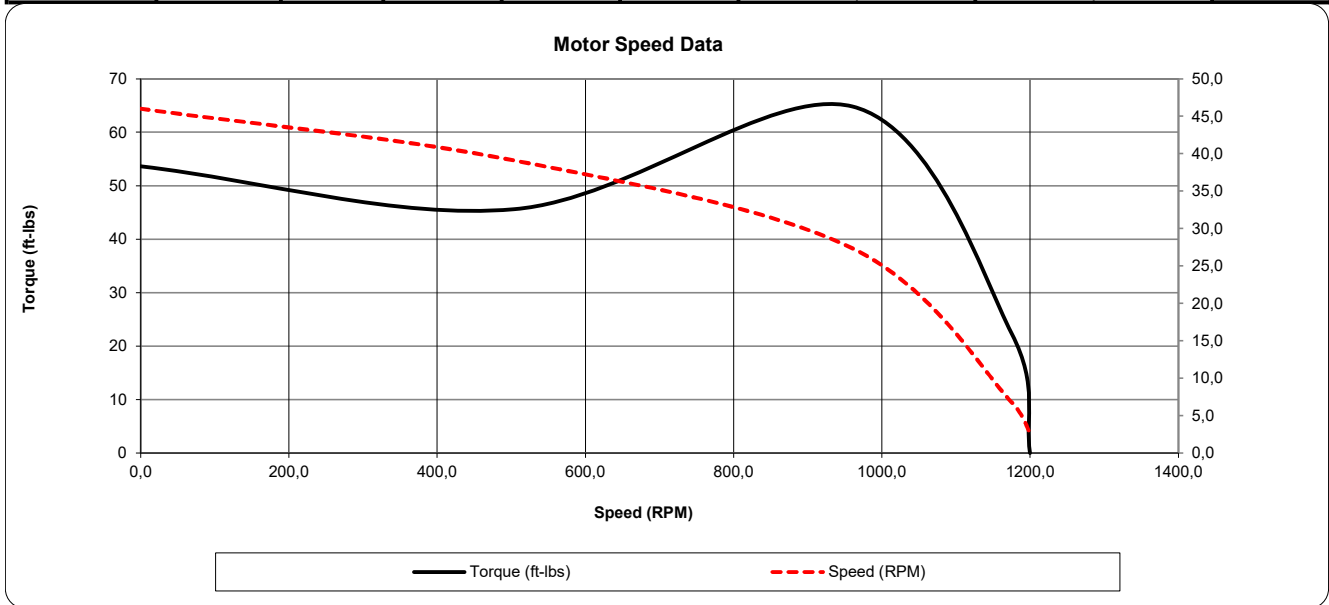

Date: 2024-01-29
 Customer: _____
 Contact: _____
 Submittee: J.C. Lavallée

Catalogue #: **MQSP-506TL**

NEMA PREMIUM NR CAN NEMA 12 - 12										
HP	VAC	RPM	Enclosure	Frame	Frequency	Design	Poles	LR Code Letter	Insulation Class	Temp. Rise °C
5	460	1175	TEFC	215TC	60	B	6	J	F	< 80
Load %	0%	25%	50%	75%	100%	125%	150%			
Amps	2,58	2,90	4,03	5,31	6,80	8,33	9,95			
Torq ft/lbs	0	5,50	11,06	16,67	22,35	28,09	33,88			
RPM	0	1193,75	1187,5	1181,25	1175	1168,75	1162,5			
Eff	0	74,68	88,90	89,80	89,50	89,50	89,50			
PF	0	33,1	62	74	76,9	78,5	78,8			
	Locked Rotor	Pull-Up	Breakdown	Rated Load	Idle	Duty	S. F.	Ambient	Elevation	dBa @ 1M
Speed (RPM)	0	504	960	1175	1200	Continuous	1,15	40°C	3,300 ft	61
Current (Amps)	46	39,1	27,4	6,8	2,584	VFD Rating: Meets MG1 parts 31.4.4.2				
Torque (ft-lbs)	53,64	45,59	64,81	22,35	0,0	CT	10:1	VT	20:1	

